

## PAD7 Ambient Dough Drawers



### DOUGH DRAWER SPECIFICATIONS

Our ambient dough drawers, designed and manufactured with the highest quality materials, are an outstanding value. The unit's seven ambient temperature drawers are designed to hold pizza dough, ingredients or utensils temporarily during the preparation period.

The unit may be purchased separately or as part of one of our complete specialty prep table units. This unit can be used for any prep table with an overall height of at least 34".

### OUTSIDE DIMENSIONS

23.25" (W) x 34" (H) x 31.25" (D)

### CAPACITY:

The top drawer accommodates a 26" x 18" x 3.25" pan/tray

The other 6 drawers accommodate a 26" x 18" x 3.5" pan/tray

**WEIGHT:** 210 lbs

### SHIPPING DIMENSIONS:

37" (W) x 38" (H) x 35" (D)

**SHIPPING WEIGHT:** 260 lbs

### STANDARD FEATURES

- Seven, ambient temperature dough drawers
- Heavy duty AISI, 20 gauge, 304 grade stainless steel used on all critical areas
- NSF approved lockable swivel casters
- Telescopic drawer guides extend from the cabinet to support the drawer when open
- Holds seven 18" x 26" pans/trays (not included)
- Meets the guideline demands of HACCP
- Fully welded seams

### WARRANTY

- Two-year warranty on parts



NSF approved locking swivel casters



Engineered in the USA

 <b>Intertek</b>	
<b>Approval:</b> NSF 2: 2015	<b>Date:</b> 04/2018

Specifications subject to change without notice.

# PAD7 Ambient Dough Drawers

FRONT VIEW

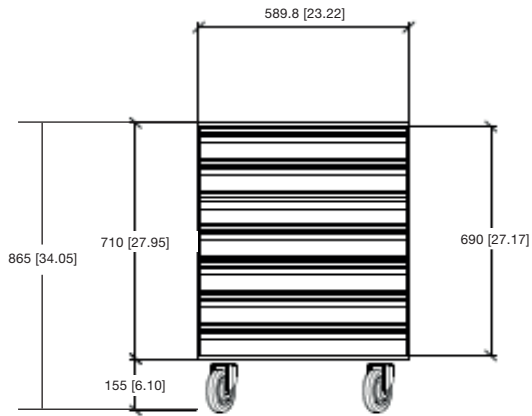

SIDE VIEW

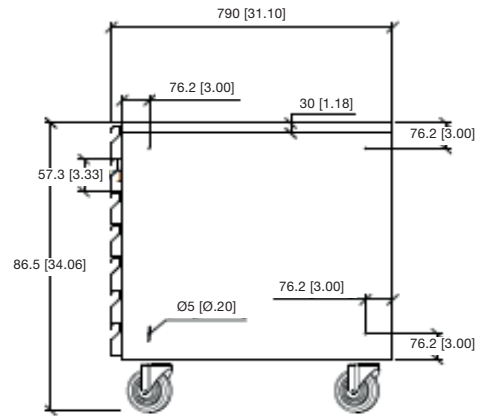

DRAWER DETAIL

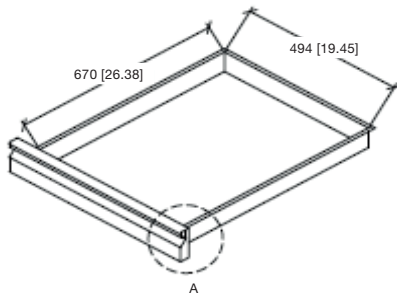

DRAWER FRONT DETAIL

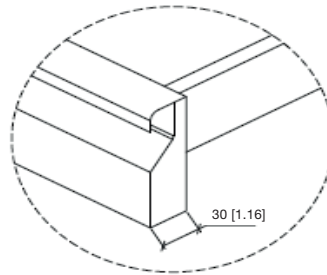

Dimensions: 23.25" (W) x 34" (H) x 31.25" (D)

Specifications				
Model	Item #	Drawers	Temperature	Material
PAD7	4820	7	Ambient	20 Gauge Stainless Steel

Specifications subject to change without notice.



Proud to be family-owned.

