

TYPE: Blast Chiller/Freezer MODEL: PBF-5.0



OPTIONAL ACCESSORIES

- Plastic coated shelves
 - UV sanitizer
 - Heated multi-point probe
 - Three core probe kit
 - Left-hand door
- Specifications subject to change without notice.

WARRANTY

- Three year warranty on parts and labor
- Additional warranty for years 3-5 on compressor (parts only)

PRODUCT DESCRIPTION

The PrepRite® PBF 5.0 is designed to integrate smoothly into professional kitchen workflows, supporting compliance with HACCP guidelines for cook/chill operations. Its ambient chill method, paired with indirect air circulation, helps deliver consistent temperature reduction to support food quality and product safety.

Manufactured with the environment in mind, the PBF 5.0 incorporates advanced technology and essential performance features designed to protect long-term investment. The result is reliable operation, improved food safety, lower utility costs, and strong overall value in today's competitive foodservice marketplace.

STANDARD FEATURES

- Ambient chill method
- Indirect air circulation to improve food quality
- HACCP compliant; self-contained refrigerated system
- Electronic touch screen control; user friendly and programmable for up to 99 recipes
- USB port; front mounted for easy access to download data, such as HACCP, or upload recipes
- Automatic hot gas defrost
- Rounded interior corners for simple cleaning
- Single point product probe
- Stainless steel rack system for pans or shelves
- Snap-in magnetic gasket for straightforward changes or cleaning
- Self-closing door, right-hand hinged
- Casters for effortless movement, front casters can be swivel, fixed or locked
- 304 Stainless steel interior and exterior front, sides, and top.
- Refrigerant: R404
- Environmentally friendly HFO insulation

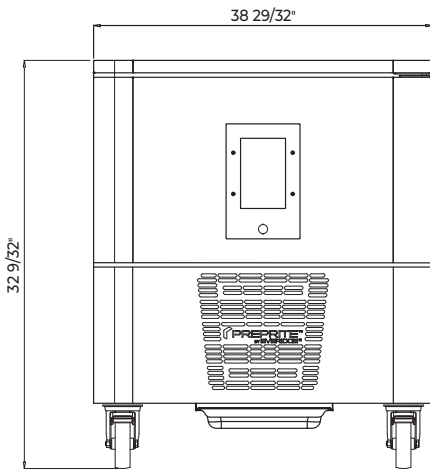

FRONT VIEW

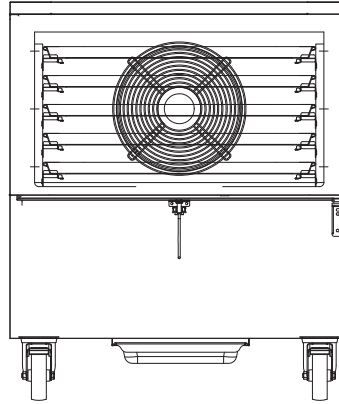

BACK VIEW

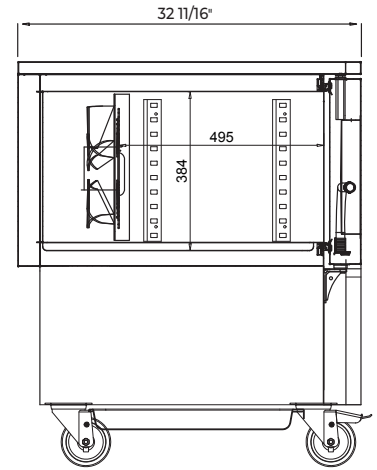

SIDE VIEW

MODEL: PBF 5.0

CAPACITY	OUTPUT CHILLING CAPACITY
5 pans 18" x 26" x 1" deep Pans not included	+194/+37°F 50 lbs within 90 minutes
DISTANCE	OUTPUT FREEZING CAPACITY
between shelves 2.69"	+194/0°F 30 lbs within 240 minutes
OUTSIDE DIMENSIONS	OUTPUT THAWING CAPACITY
32.25" (W) X 32.625" (D) X 38.75" (H)	0°F/38°F 10 lbs within 240 minutes
INTERIOR DIMENSIONS	0°F/38°F 20 lbs within 480 minutes
27.5" (W) x 19.5" (D) x 15" (H)	0°F/38°F 30 lbs within 720 minutes
WEIGHT	HEAT LOAD BTU/HR
255 lbs	5,820- 10° F evaporator temperature/104° F ambient
SHIPPING DIMENSIONS	ELECTRICAL SUPPLY
34" (W) X 34" (D) X 48" (H)	115-120 V/1 PH/60 Hz
SHIPPING WEIGHT	RLA/LRA/MOP: 5.2/66/15
290 lbs	20A circuit, # 12 wire required

Notes: The installation of the blast chiller/freezer and the installation of the remote condensing unit must be performed by a qualified professional. All specifications are subject to change without notice.

