

Project Name : \_\_\_\_\_

Location : \_\_\_\_\_

Item # : \_\_\_\_\_

**TYPE: 3-Rack 1200 lbs Blast Chiller MODEL: PBC-1200-TS-CAB-1DR**

## BLAST CHILLER SPECIFICATIONS

The standard modular blast chiller solution includes the panel walk-in, evaporator, and condensing unit. The high-capacity unit is well suited to a high-volume professional kitchen workflow, making it possible to improve your kitchen efficiency and food quality while staying within HACCP guidelines.

Standard features include a NEW advanced touch screen controller with USB port, holding cycle (once your cycle is completed the unit automatically switches over to a cooler), a single point product core probe, and up to 99 customized recipe programs.

## STANDARD FEATURES

- New advanced 7" Gorilla glass touch screen controller with USB port on easy-to-use control panel
- Holding cycle: automatically switches over to holding mode after each cycle is completed
- Evaporator is enclosed in a frame and cabinet
- User-initiated defrost cycle
- One single point product core probe registers product temperatures
- Meets the demands of HACCP guidelines for proper food chilling
- Defrost Capabilities
- Automatic defrost termination
- Programmable controller with up to 99 customized options

## A COMPLETE SOLUTION

The package includes a PrepRite<sup>®</sup> walk-in, perfectly designed to fit your blast chiller needs. The walk-in is available with 1 or 2 doors, external ramp, 8" deep interior ramp designed to accommodate 3 roll-in racks up to 40" x 40" x 76" each and features our exclusive anti-bacterial Sanisteel<sup>®</sup> interior metal finish.

It also includes an air cooled, remote, outdoor condensing unit as standard. Other condensing unit options, including indoor and water-cooled models are available on request.

## WARRANTY

- 2-Year Parts & Labor Warranty
- Additional warranty for years 3-5 on compressor (parts only)



### EVAPORATOR OUTSIDE DIMENSIONS

28.8" W x 16.67" D x 72.08" H (per evaporator coil)

### OUTPUT CHILLING CAPACITY\*

194°F to 38°F within 90 minutes

### CAPACITY (BTU/HR) AT -10°F SST/ +104°F

127041

### PEAK CAPACITY (BTU/HR) AT +14°F SST/ +116.6°F

200458

### REFRIGERANT

R448A

### HEAT LOAD BTU/HR

79,380/-10°F SST/+95°F ambient

### ELECTRICAL SUPPLY

1 PH/208-230 V/60 Hz

20 A circuit

### AIRFLOW CAPACITY

22364

**Notes:** The installation of the blast chiller and the installation of the remote condensing unit must be performed by a qualified professional. All specifications are subject to change without notice.

The output chilling and freezing capacity rating conditions and values have been calculated using the product's internal temperature.

**Notes:** \* Performance ratings for this unit based on exterior dimensions of 64.5" W x 123" D x 88"H. Your performance results may vary based on the interior dimensions of your unit and the characteristics of the food being processed. Contact your regional sales person for more information.

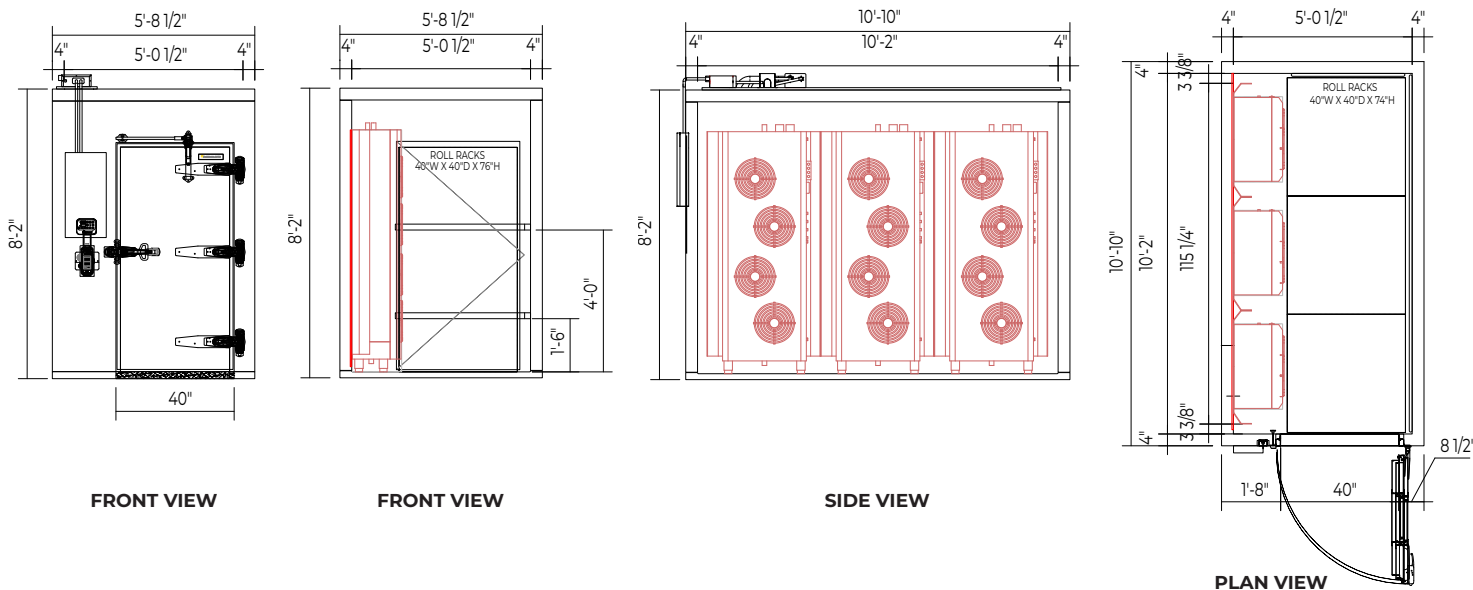

EVAPORATOR MODEL	DIMENSIONS				
	OUTSIDE			SHIPPING	
	WIDTH	DEPTH	HEIGHT	DIMENSIONS	WEIGHT
PBC1200-TS 5980	28.8"	16.67"	72.08"	81" x 41" x 19.5"	400 lbs
includes three evaporator coils					

PBC1200 WALK-IN DIMENSIONS (ins)		
OUTSIDE		
WIDTH	DEPTH	HEIGHT
64.5	123	88

MAXIMUM LOAD PER CYCLE	ELECTRICAL DATA					REFRIGERATION DATA		
Chill	Volts	Hz	Phase	Amps	Circuit Amps	Refrigerant	Suction Line	Liquid Line
1200 lbs	208-230	60	1	12	20	R448A	1.38	0.38

**OUTDOOR  
REMOTE CONDENSING UNIT  
PBC-1200-R448-CU-208/230  
P/N 5967**

All dimensions in inches

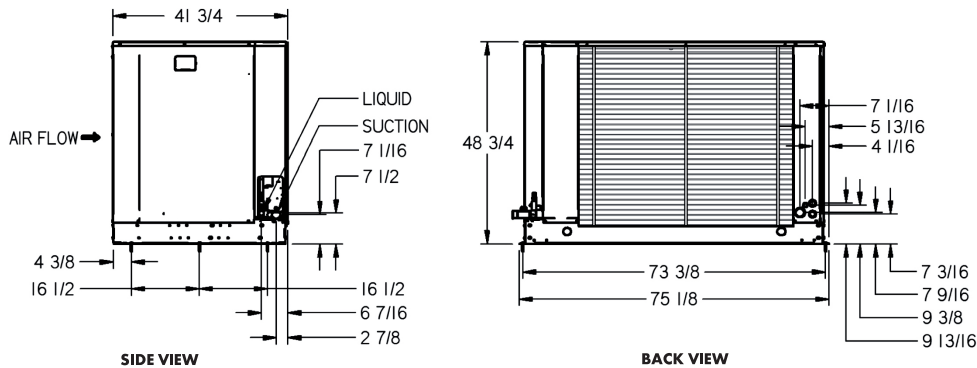

ELECTRICAL DATA - SUPPLY 3 PH/208-240 V/60 Hz											
Compressor(s)		Fan Motor(s)			Electric Ratings						
RLA	LRA	Qty.	Hp	FLA	Defrost Heater (W)	High or Low Amps	Contactors	MCA	MOPD	Evap. Fan Amps	Defrost Heater Amps
47.2	278	2	3/4	4.4	2700W	N/A	N/A	67.8	110	N/A	N/A

UNIT SPECIFICATIONS									
Refrigerant	Connections (ins)		Receiver 90% Full (lbs)		Fan Blade(s) Dia. (ins)	Sound Data (dB)	Approx. Net Weight (lbs)	Shipping Weight (lbs)	Shipping Dims. (ins) L x W x H
	Liquid Line	Suction	Standard	Oversized					
R448A	0.875	1.625	87	98	24	82	1234	1491	41.75 x 75.125 x 48.75

**Notes:** The installation of the blast chiller/freezer and the installation of the remote condensing unit must be performed by a qualified professional. All specifications are subject to change without notice.

