

Project Name : _____

Location : _____

Item # : _____

TYPE: 1-Rack 450 lbs Blast Chiller & 270 lbs Shock Freezer **MODEL:** PBF-450-TS-CAB-IDR

CHILLER/FREEZER SPECIFICATIONS

The standard modular blast chiller and shock freezer solution includes the panel walk-in, evaporator, and condensing unit. The high-capacity unit is well suited to a high-volume professional kitchen workflow, making it possible to improve your kitchen efficiency and food quality while staying within HACCP guidelines.

Standard features include a NEW advanced touch screen controller with USB port, holding cycle (once your cycle is completed the unit automatically switches over to a cooler), a single point product core probe, and up to 99 customized recipe programs.

STANDARD FEATURES

- New advanced 7" Gorilla glass touch screen controller with USB port on easy-to-use control panel
- Holding cycle: automatically switches over to holding mode after each cycle is completed
- Evaporator is enclosed in a frame and cabinet
- User-initiated defrost cycle
- One single point product core probe registers product temperatures
- Meets the demands of HACCP guidelines for proper food chilling
- Defrost Capabilities
- Automatic defrost termination
- Programmable controller with up to 99 customized options

A COMPLETE SOLUTION

The package includes a PrepRite[®] walk-in, perfectly designed to fit your blast chiller/freezer needs. The walk-in is available with 1 or 2 doors, external ramp, 8" deep interior ramp designed to accommodate 1 roll-in rack up to 40" x 40" x 76" and features our exclusive anti-bacterial Sanisteel[®] interior metal finish.

It also includes an air cooled, remote, outdoor condensing unit as standard. Other condensing unit options, including indoor and water-cooled models are available on request.

WARRANTY

- 2-Year Parts & Labor Warranty
- Additional warranty for years 3-5 on compressor (parts only)



EVAPORATOR OUTSIDE DIMENSIONS

28.8" W x 16.67" D x 72.08" H (single evaporator coil only)

OUTPUT CHILLING CAPACITY*

194°F to 38°F within 90 minutes

OUTPUT FREEZING CAPACITY*

194°F to 0°F within 240 minutes

CAPACITY (BTU/HR) AT -10°F SST/ +104°F

43378

PEAK CAPACITY (BTU/HR) AT +14°F SST/ +116.6°F

68549

REFRIGERANT

R448A

HEAT LOAD BTU/HR

41,780/-10°F SST/+95°F ambient

ELECTRICAL SUPPLY

1 PH/208-240 V/60 Hz

20 A circuit, # 12 wire required

AIRFLOW CAPACITY

5591

Notes: The installation of the blast chiller and the installation of the remote condensing unit must be performed by a qualified professional. All specifications are subject to change without notice.

The output chilling and freezing capacity rating conditions and values have been calculated using the product's internal temperature.

Notes: * Performance ratings for this unit based on exterior dimensions of 64.5" W x 50" D x 88"H. Your performance results may vary based on the interior dimensions of your unit and the characteristics of the food being processed. Contact your regional sales person for more information.

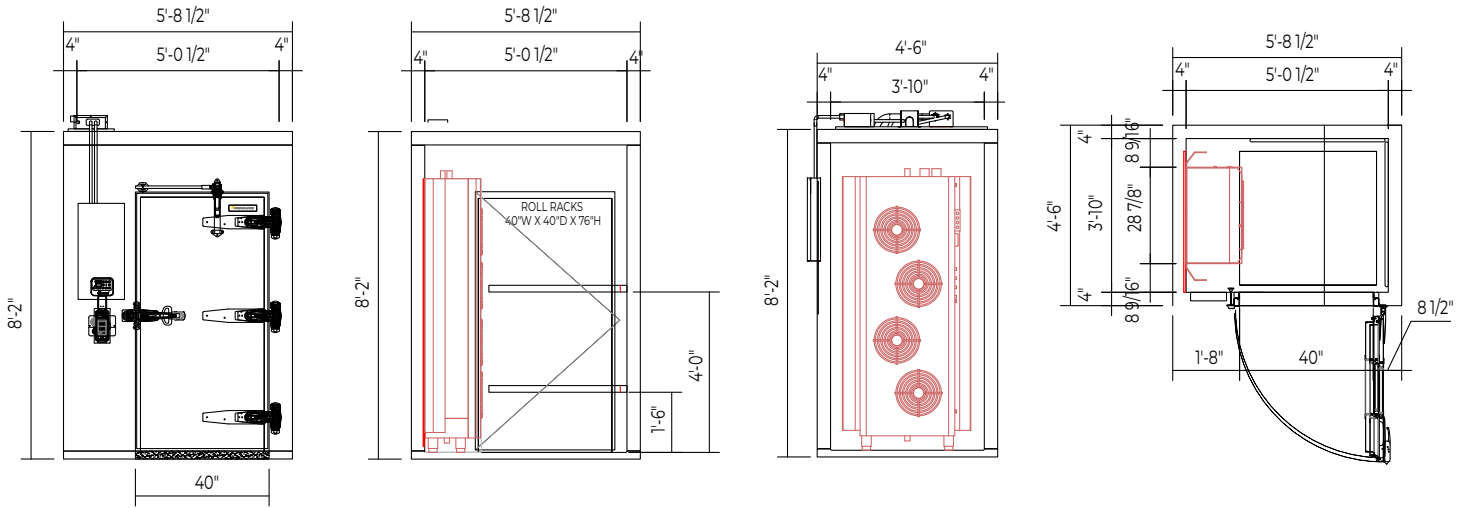

FRONT VIEW

FRONT VIEW

SIDE VIEW

PLAN VIEW

EVAPORATOR MODEL	DIMENSIONS				
	OUTSIDE			SHIPPING	
	WIDTH	DEPTH	HEIGHT	DIMENSIONS	WEIGHT
PBF450-TS 4507	28.8"	16.67"	72.08"	81" x 41" x 19.5"	400 lbs

PBF450 WALK-IN DIMENSIONS (ins)		
OUTSIDE		
WIDTH	DEPTH	HEIGHT
64.5	50	88

MAXIMUM LOAD PER CYCLE		ELECTRICAL DATA					REFRIGERATION DATA		
Chill	Freeze	Volts	Hz	Phase	Amps	Circuit Amps	Refrigerant	Suction Line	Liquid Line
450 lbs	270 lbs	208-240	60	1	8.92	20	R448A	1.38	0.38

**OUTDOOR
REMOTE CONDENSING UNIT**
PBF-450-R448-CU-208/230
P/N 5906

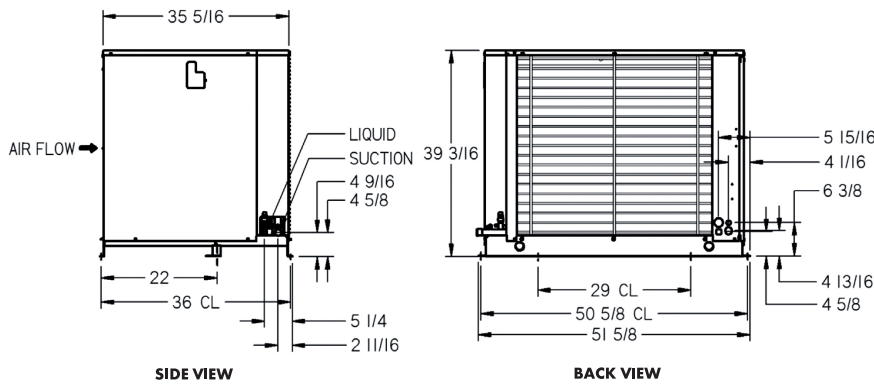

All dimensions in inches

ELECTRICAL DATA - SUPPLY 3 PH/208-240 V/60 Hz

Compressor(s)		Fan Motor(s)			Electric Ratings						
RLA	LRA	Qty.	Hp	FLA	Defrost Heater (W)	High or Low Amps	Contactors	MCA	MOPD	Evap. Fan Amps	Defrost Heater Amps
27.6	161	1	1/3	2.7	900W	High Amps	1	75	80	20	60

UNIT SPECIFICATIONS

Refrigerant	Connections (ins)		Receiver 90% Full (lbs)		Fan Blade(s) Dia. (ins)	Sound Data (dB)	Approx. Net Weight (lbs)	Shipping Weight (lbs)	Shipping Dims. (ins) L x W x H
	Liquid Line	Suction	Standard	Oversized					
R448A	0.5	1.125	28	52	22	81	805	992	36.75 x 51.75 x 39.25

Notes: The installation of the blast chiller/freezer and the installation of the remote condensing unit must be performed by a qualified professional. All specifications are subject to change without notice.

